

Specialists in Engineering Solutions for the Recycling and Material Handling Sectors



The Anaconda Range of Mobile Tracked **Jaw** Crushers are designed specifically to suit applications where the toughest demands of primary crushing are of imperative importance with their immense power, reliability and productivity.

The **J12** Jaw Crusher is an aggressive and powerful mobile Jaw Crusher, Boasting the proven ability of the Universal Crushers Jaw Chamber 1100mm x 700mm (28" x 44") within an innovative Anaconda Tracked Solution.

The **J12** utilizes an extremely fuel efficient and powerful **Hydraulic System** which allows the machine to provide excellent levels of productivity in applications such as Recycling, Contracting and Quarrying. The physical size, quick set up time, user friendly controls and ease of transport make the **J12** the perfect crushing solution. Additionally, with a capacity of up to 300TPH the **J12** is sure to make light work of the toughest scenarios.



Head Quarters:
Anaconda Equipment 'A McLanahan Company',
Ardboe Business Park,
Kilmascally Road,
Dungannon, Co. Tyrone
BT71 5BJ



Contact us :

Tel - +44 (0) 28 86737878
Fax - +44 (0) 28 867 36675
Email - sales@anacondaequipment.com

Specialists in Engineering Solutions for the Recycling and Material Handling Sectors

SPECIFICATIONS AND TECHNICAL DETAILS

Features

- Universal Crushers Jaw Chamber (1100mm x 700mm)
- All Hydraulic Toggle and Tension Rod set-up
- Direct hydraulic drive (1340cc Motor)
- CSS Range (50mm – 190mm)
- Jaw speed range (250, 265–280 RPM)
- Hydraulically folding Hopper Wing-plates
- Hopper Max Capacity 6.5m³
- Variable Speed on discharge conveyors
- Overband Magnet (Dual side discharge)
- Aggressive vibrating pan feeder with two stepped grizzly sections

Engine

- Cummins IPU – Stage 5 – (283Kw)

Options

- Blank hardox/domex mesh to by-pass fines conveyor
- Level sensor to stop/start the feeder when Jaw becomes too full
- Deflector plate beneath the Jaw Chamber
- Alternative Jaw Profiles available dependant on application

Weight

- 45,350 KG

WORKING AND TRANSPORTATION DIMENSIONS

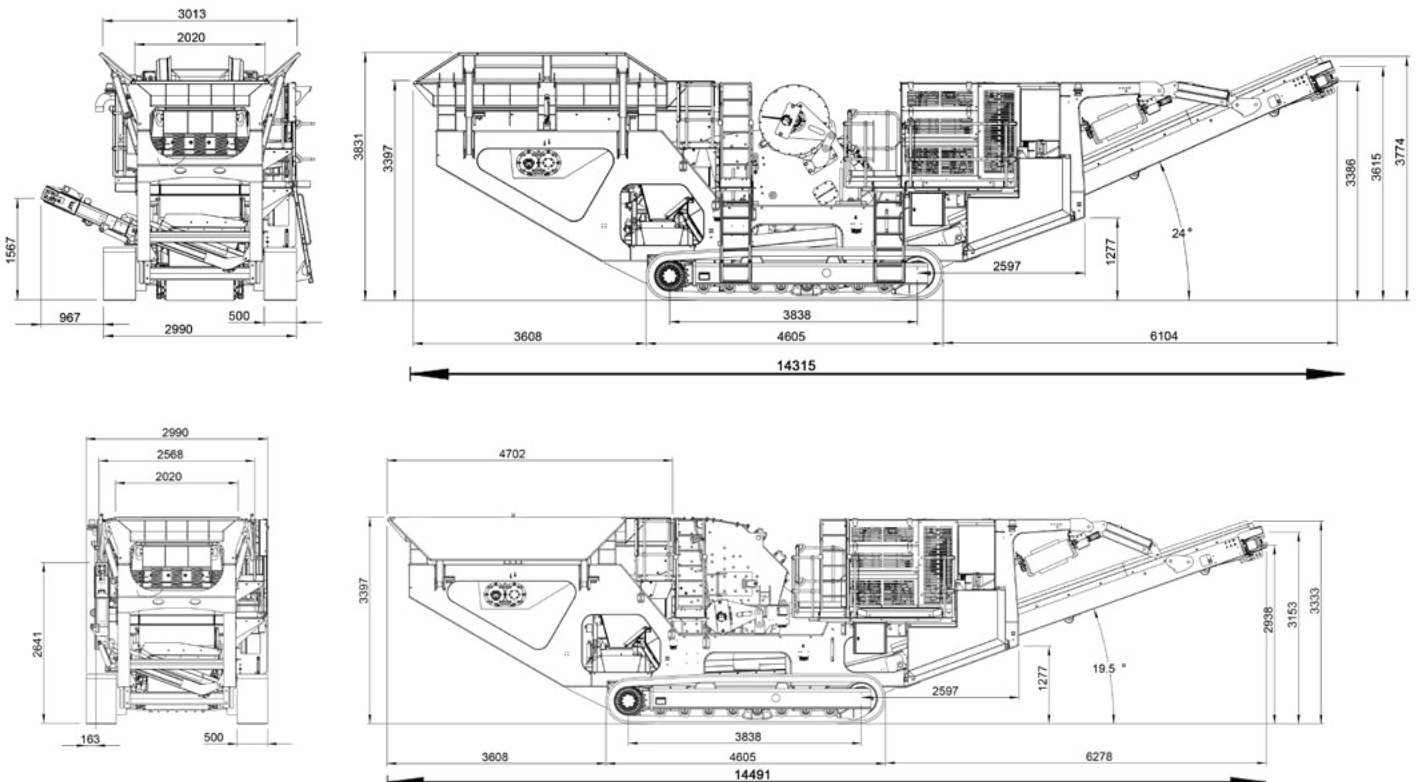

Anaconda sell and distribute our entire product portfolio via a Dealer Network,
For your nearest dealer please contact us or visit our website.
Anaconda reserves the right to make changes to design without reservation and without notification.
Tonnage estimations are dependent on fractions, material type, size and application.

WWW.ANACONDAEQUIPMENT.COM

FOLLOW OUR SOCIAL MEDIA CHANNELS

