



mobile slow-speed shredder MRW 2.1010

The Pronar MRW 2.1010 slow-speed shredder is the largest machine in the offer, designed to work in large installations. Its heart is the Volvo Penta 796 HP engine (without DPF filter), which, combined with load sensing hydraulics and two hydraulic motors per shaft, allows you to deal with difficult materials. The working chamber is 2.44 m long and the chute capacity is 4.5 m³, which makes it possible to work even with large loaders. The weight of 44 tons (depending on the configuration) is a guarantee of solid construction with the use of thick steel, especially in sensitive points exposed to high stress. The MRW 2.1010 shredder is also designed for easy service. Machine draining points are located on the outside for easy access. There is also enough space inside the shredder to be able to carry out all necessary repairs in comfortable conditions.

KEY FEATURES & BENEFITS

- | high efficiency
- | the ability to work even with difficult materials
- | homogeneous final fraction
- | only toughest steel grades guarantee solid construction
- | easy service access

APPLICATION

- | wood
- | wood-based materials
- | municipal waste
- | large-size
- | industrial waste
- | tires
- | scrap metal
- | car bodies (without engines and axles)
- | mattresses



TECHNICAL DATA

MRW 2.1010

Dimensions (length/width/height) [mm]	9470/3000/3230
Weight [kg]	~44000*
Number of shafts	2
Shafts length [mm]	2440
Loading height [mm]	3230
Working chamber dimensions (length/width) [mm]	2440/2880
Hopper capacity [m ³]	~4,5
Engine	Volvo Penta 16.1I, 585 kW, Stage V/Tier 4 Final

* Weight depends on the specification of the individual piece and may be higher

MRW 2.1010

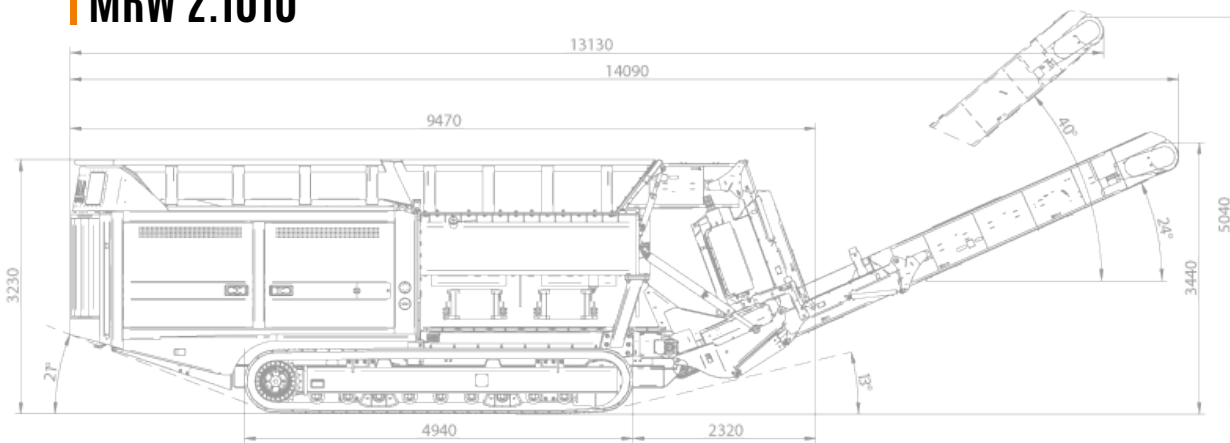

WE MAKE RECYCLING EASY.

PRONAR Sp. z o.o.

📍 ul. Mickiewicza 101A | 17-210 Narew | Poland

☎ +48 85 682 71 00

